

**NEW** 3DX | **eco**XPERT

**eco**  
**XPERT**



LOADED  
WITH  
**30** INNOVATIVE  
FEATURES

**GET AHEAD OF YOUR GAME**  
WITH THE NEW 3DX POWERED BY INTELLI PERFORMANCE.

**JCB**

# 75 years of innovation

We've been innovating since day one, and we've always cultivated a uniquely fearless approach to design. The constant innovation and growth for more than 75 years, has led JCB to provide the world's best backhoe loader range with a total population of over 7 50 000 machines.

JCB Backhoe Loaders, introduced in the year 1953 revolutionised the construction industry in a very short span of time with its multifarious application usage, which gradually made us the leading backhoe loader manufacturer globally. In India, more than 3 00 000 backhoe loaders are on the road, and for us it is not just a matter of pride but a true demonstration of sheer excellence and precision.

Presently, JCB has a strong brand presence in India, which is a true testament to our belief of "Always looking for a better way".



# INTRODUCING THE NEW 3DX

Powered with IntelliPerformance



IntelliPerformance is a uniquely developed machine system that is continuously reacting to the changing demands of the operator and application. The system effectively manages the energy demand from the hydraulic & powertrain to give a perfectly optimised performance.

This innovative technology is another example of JCB's "Intelligent Machines" strategy to further reduce fuel consumption whilst delivering legendary 3DX performance.



**12%\***  
**MORE**  
FUEL EFFICIENCY

**22%\***  
**REDUCED**  
MAINTENANCE COST

2 Excavation Operating Modes

Auto Stop

Intelli Diagnostics

Guide me Home

Advanced LiveLink

\*T&C Apply. Against the current 3DX, tested under controlled environment.

LOADED WITH  
**30** INNOVATIVE  
FEATURES



**12%\* More Fuel Efficient**

Variable Displacement Hydraulic pump provides a potential of saving an additional ₹80 000/year.



**Auto Stop**

An inbuilt feature that automatically shuts the engine off after 6 minutes of inactivity thereby, saving fuel and money.



**22%\* Less Maintenance Cost**

Extended hydraulic oil changed period - 4 000 hrs from 2 000 hrs, saving ₹20 000/year.



**No Contact Fuel Level Sensor**

New fuel sensor design that is more reliable and suits all types of fuel providing accuracy in reading and a longer life in various fuel conditions.



**Wear Pads Rust Proof Lock Nuts**

The Wear Pad Lock Nuts are now coated with a rust proof coating to enhance the life of internal threads. This provides ease of tightening and replacement.



**Wider Dipper\***

Wider dipper with extra metal enhances life.



**Date & Time Information\***

Be on the move with date & time information on the display.



**Inner Rear View Mirror**

Provides assistance to operator to see rearwards.



**Ambient Temperature Information**

Be updated on ambient temperature.



**Improved Life of Pins and Bushes**

Extended life of boom and dipper joint pins as well as bushes make the machine more reliable.



**Digital Speedometer**

Operation made easy with an advanced Digital Speedometer that displays speed with clarity.



**Economy & Standard Mode\***

The eco mode gives better fuel efficiency and standard mode gives more productivity.



**Trip Hour Meter (Kms)**

Keep track of the distance covered.



**Hydraulic Filter Clogging Indicator**

Get alerts about the clogging of hydraulic filter, thus, enhancing the life of hydraulic components.





## Smooth Gear Shift

The Smooth Gear Shift, provides the operator with comfort and ease of operation for enhanced productivity.



## Bluetooth Stereo & Telephony

Ensure a fatigue-free and relaxed operation with Bluetooth stereo.



## Advanced LiveLink

Advanced LiveLink, an innovation that gives you the additional facility of data analytics about the operational behaviour of your machine.



## New Improved Seat

Ergonomic seat for longer duration of operation without fatigue.



## Trip Hour Meter (Hours)

Keep track of the work done in hours.



## SOS Switch

Safety and security taken-up a notch higher with the SOS switch that connects the operator with the LiveLink command centre or owner, in case of any emergency.



## Sunscreen & Tinted Glass

The Sunscreen and Tinted Glasses ensure comfortable operation, as the eyes of the operator are always protected from the glare of the sun.



## Informative Digital Cluster Display

Informative display for ease of operation.



## Guide Me Home

The external lights switch-on after ignition is off, when the machine is parked in the dark. This helps the operator to reach a safer distance securely, switching off automatically after 30 seconds.



## New Styling Roof

New stylised roof for better rainwater management increasing uptime in rainy seasons.



## LED Rear Work Lamp

LED Rear work lamps for improved visibility at night.



## Service Interval Reminder

Never miss or delay the service of your machine with service interval reminders on the Informative cluster.



## New External Styling

Refreshed external looks and roof structure.



## Coolant Indicator on Radiator

Coolant Indicator window makes it easy to know coolant level, thus, safeguarding engine heating and increasing uptime.



## Replaceable Breather Element on Hydraulic Tank

Breather Element on hydraulic tank can be replaced separately, increasing the pump and oil life, saving cost.



## Intelli Diagnostics

A Smart App is connected to the machine via Bluetooth which enables quick identification of concerns.

\*T&C Apply. Against the current 3DX, tested under controlled environment.

## BIG SPACIOUS CABIN WITH EASY OPERATION

Informative digital cluster with an audio-visual warning system displays any malfunctioning along with ERROR code enabling the service engineer to be prepared before he arrives at the site.

New improved cabin interiors with better seat and bluetooth stereo to ensure fatigue-free operation.

Operation made easy with an advanced digital speedometer that displays speed with clarity.

The sunscreen and tinted glasses ensure comfortable operation, as the eyes of the operator are always protected from the glare of the sun.

IntelliDiagnostics enables quick identification of concerns. A service engineer can quickly resolve a critical concern enhancing the uptime.

Coolant Indicator window makes it easy to know coolant level, thus, safeguarding engine heating and increasing uptime.

Get alerts about the clogging of hydraulic filter with the advanced hydraulic filter clogging indicator, thus, enhancing the life of hydraulic components.



# Informative digital cluster display

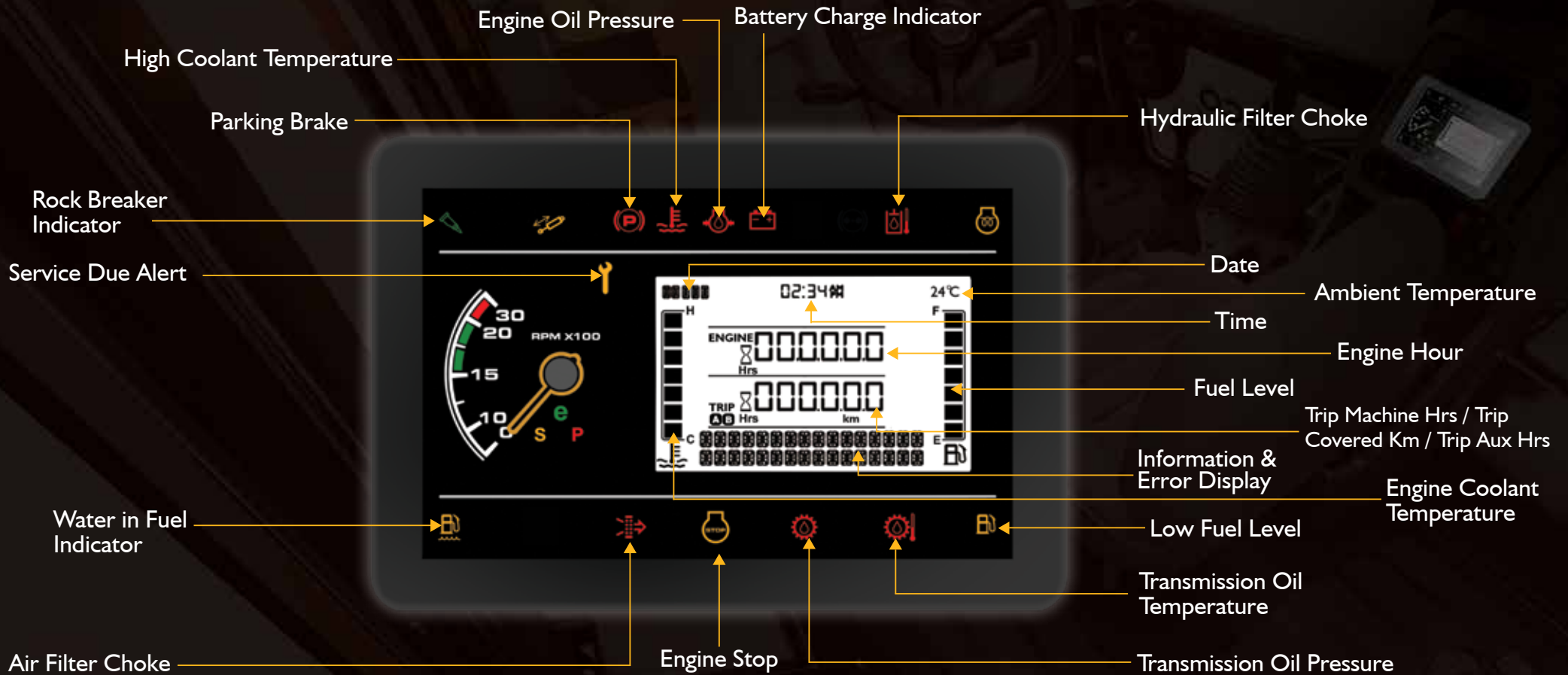

## INTELLIDIG

IntelliDig<sup>#</sup> is a smart monitoring system that assists you in all kind of digging operations for maximum productivity, ease of use and safety. Installed with sensors, this intelligent backhoe loader guides you in specific depth requirements eg. gas pipeline laying, fibre optics, drainage and trenches. The system also ensures protection to existing system like pipeline, cables and overhead lines.



### Dig profile selection

Dig profile selection - with a choice of flat surface, rectangle, downhill slope & uphill slope modes, do accurate digging with ease and in lesser time.



### Real time indication

Get real time depth, reach and slope indications with visual and audio warnings including height warning alert on the Informative cluster, for more optimised digging, ensuring more fuel savings.



### Receptive sensors

The highly receptive sensors are located on the bucket link, boom, dipper & chassis, ensuring intelligent monitoring throughout the digging operation.



#Optional feature

## ADVANCED CONNECTIVITY

### STAY CONNECTED 24X7

Now be assured of your JCB Backhoe Loader's service, operation and security with the advanced telematics technology called LiveLink.



#### Service



Service reminder



Machine data backup



Critical machine health alerts

#### Operation



Machine utilisation report



Fuel level information



Engine status



Data analytics

#### Security



GPS tracking



Possible intrusion/  
Tow away alerts



Operating hours/  
Time fencing



Geofencing



## SERVICE & SUPPORT

### MAXIMISE YOUR PROFITABILITY AND REDUCE DOWNTIME

JCB's certified engineers are there to maximise your profitability and reduce downtime.

Our engineers are always there to serve the customers and provide value-added solutions to all their concerns regarding the machines and services.



JCB trained and certified engineers



Best-in-class service and repairs



On-site training and support

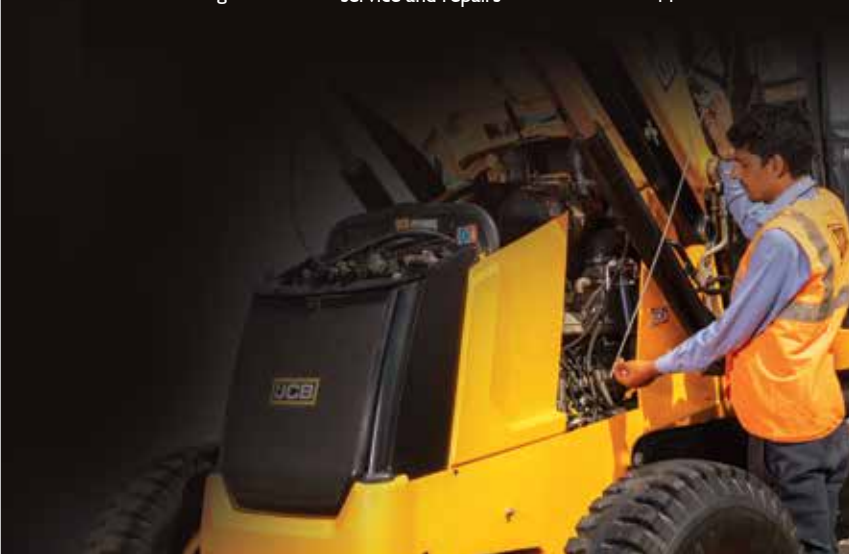

## EXTENDED CARE

### GIVE YOUR MACHINE EXTENDED WARRANTY AND CARE.

- JCB Careplus is an extended warranty programme that comes into effect after the machine standard warranty expires.
- JCB Careplus can be purchased within the 1<sup>st</sup> year from the sale of the machine.
- The programme offers you peace of mind and saves your maintenance cost even after your machine standard warranty expires.



Extended Warranty Programme



### BENEFITS OF JCB CAREPLUS



No limits on number of claims



Preventive maintenance service\*



Nationwide coverage\*\*



JCB skilled manpower support



Maximum productivity



Maximum uptime



Maximum performance



Breakdown cost protection



Better resale value

\*Varies on JCB Careplus package selected.  
\*\*All services completed in line with the JCB recommended service interval schedule.

PERFORMANCE DIMENSIONS

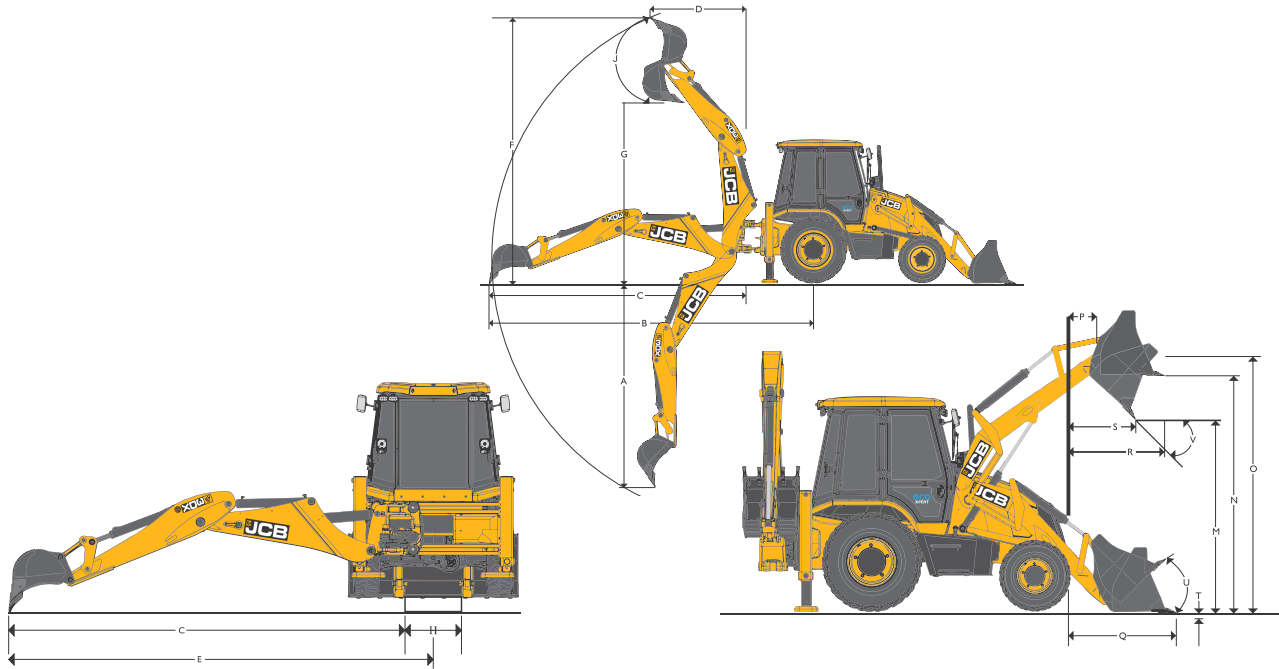

STATIC DIMENSIONS

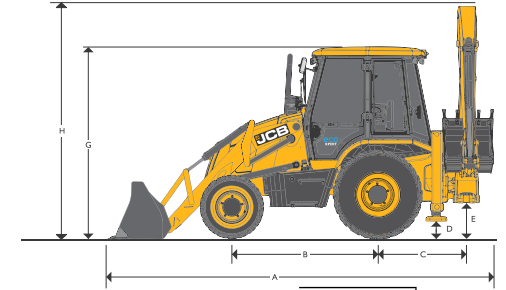

	m	3DX
A Overall length	m	5.90 (19.4)
B Wheelbase	m	2.17 (7.1)
C Slew centre to rear axle centre	m	1.32 (4.4)
D Minimum ground clearance	m	0.31 (1.017)
E Slew ground clearance	m	0.51 (1.9)
G Height to top of cab	m	2.87 (9.5)
H Overall height	m	3.61 (11.10)
J Track width - Rear	m	1.73 (5.8)
K Track width - Front	m	1.86 (6.1)
L Width over bucket	m	2.35 (7.9)

EXCAVATOR PERFORMANCE

		3DX
A Max. dig depth	m	4.77 (15.8)
B Reach-ground level to rear wheel centre	m	6.72 (22.1)
C Reach-ground level to slew centre	m	5.40 (17.9)
D Reach at full height to slew centre	m	2.74 (8.12)
E Side reach to centre line of machine	m	6.02 (19.9)
F Max. working height	m	5.97 (19.7)
G Max. load over height	m	4.18 (13.9)
H King post travel	m	1.06 (3.6)
J Bucket rotation - Power	deg	185
Bucket tear out force	kgf	5 700
Dipper tear out force	kgf	3 010
Lift capacity to bucket pivot at full reach (No bucket fitted) (SAE J31) (Data with standard dipper)	kg	1 490
Standard bucket capacity	cu.m	0.26 (9.18)
Standard bucket width	m	0.79 (2.7)

LOADER PERFORMANCE

		3DX
M Dump height	m	2.74 (8.12)
N Load over height	m	3.32 (10.11)
O Pin height	m	3.54 (11.7)
P Pin forward reach	m	0.25 (0.10)
Q Reach at ground	m	1.42 (4.8)
R Max. reach at full height	m	1.15 (3.9)
S Reach at full height - Bucket dumped	m	0.78 (2.7)
T Below ground level dig depth	m	0.07 (0.3)
U Rollback at ground	deg	45
V Dump angle	kgf	38
Shovel breakout force	kgf	5 272
Loader arm breakout force	kgf	5 300
Payload	kgf	1 800
Standard shovel	cu.m	1.1 (38.85)

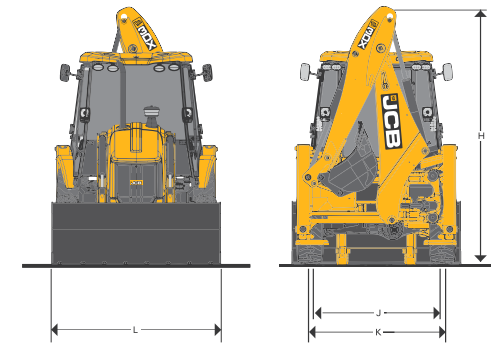

## ENGINE

JCB 448, naturally aspirated, 4 cylinder, water cooled, Diesel Engine

**Displacement** : 4.8 litres

**Gross power** : 36 kW (49 hp) @ 2 000 RPM

**Max torque** : 240 Nm (24.5 kg-m) @ 1 200 RPM

## TRANSMISSION

The JCB synchroshuttle transmission provides superb drive power in all conditions. It consists of a 4-speed, fully synchromesh, smooth shift gear box with integral torque convertor and electrically operated reversing shuttle.

- Easy-to-use, column mounted electric reversing shuttle switch can change machine direction while allowing the operator to keep hands on the steering wheel, leading to fast cycle time.
- The pedals' layout and conventional 4-pattern gear lever with transmission disconnect switch adds to the overall ease of operation. On-the-move gear changes are possible.
- Torque converter stall ratio is 3.01:1.

## AXLES

- **Rear** : Drive axle rigidly mounted, incorporates JCB Max-Trac torque proportioning differential, driven by short prop shaft from gear box.
- **Front** : Steer axle, centrally pivoted, with oscillation angle of 16°.

## BRAKES

- **Service** : JCB 'Q' brakes, hydraulically actuated, dual line, self adjusting (compensated), oil immersed, multi-disc type on the rear axle, well protected from dirt, water etc. requiring no maintenance. Operated through independent pedals linked together for normal use.
- Two independently operatable foot pedals enable machine to manoeuvre in tight spaces.
- **Parking** : Hand operated, disc brakes on rear axle input disc.

## STEERING

Power track steering rod system provides equal turn steering & quick response with less operating force.

- Working pressure 2 320 p.s.i. (160 bar)
- Oil supply from steering pump passing through suction strainer & return line.

## ELECTRICALS

130 Ampere-hour 12 Volts battery system with alternator and full road lighting.

## TYRES

Front : 9 x 16 - 16 PR  
Rear : 16.9 x 28 - 12 PR

## TURNING CIRCLE

Inner wheels not braked		3DX
A* Outside loader bucket	m	8.64 (28.4)
B Outside wheels	m	6.20 (20.4)
Inner wheels braked		
A* Outside loader bucket	m	11.6 (38.1)
B Outside wheels	m	8.94 (29.4)

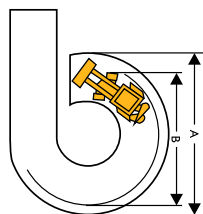

\* Standard bucket in travel position

## SPEED

Gear	Forward Km/hr	Reverse Km/hr
1st	4.5	4.5
2nd	7.3	7.3
3rd	15.4	Not recommended
4th	32.3	Not recommended

(Above is with standard tyres & assuming zero torque converter slip @ 2000 RPM)

## HYDRAULICS

Filtration through suction strainer and return line "JCB filtromatic filter".

System pressure (p.s.i.)	3 850
Pump flow (lpm) @ 2000 rpm	114

All dimensions, weights and timings are variable within 1.5%, JCB reserves the right to change specifications without prior notice.

## SHIPPING WEIGHT

7 510 kg

## SERVICE

	System
Hydraulic system	92
Fuel tank	128
Engine coolant	16.5
Engine oil	15
Transmission	17.5
Rear axle	20

## CABIN

- LED Worklamp on excavator end for better night time visibility and safety.
- New stylish roof with improved rainwater management system
- Informative digital cluster display with new features like service reminders, date, time, ambient temperature, trip meter (hour & km) & error codes display for machine diagnostics.
- Tinted cab glasses provide excellent all round visibility & sun protection.
- Sunscreen on front windscreen enables operator to focus while working at full height e.g. truck loading.
- Guide me home & SOS Switch for operator safety & ease. Autostop feature allows fuel saving.
- A fully adjustable suspension seat combined with ergonomically positioned controls and soft touch steering wheel & standard fit Bluetooth enabled music system.
- Cab provides easy 'walk through' two door access. Other features include seat belt, large convex rear view mirror inside cabin, interior light, front screen wiper, cabin fan, front and rear horn, hazard warning system, tool box and helper seat.
- Instrumentation panel is positioned on the right hand side and includes engine speed, engine hours, trip meter, fuel level, water temperature and mobile charger.
- Audio and visual fault warning system for alternator charge, coolant temperature, engine oil pressure, blocked air filter, transmission oil pressure and temperature and hand-brake on.

## LIVELINK

Advanced telematics technology that enables you to monitor and manage your machines remotely by providing information:

**Service** : Routine maintenance information and alerts

**Operation** : Health alerts & usage data

**Security** : Machine location & movement data

## OPTIONS

- Excavator buckets Capacities: 0.06 cu.m, 0.09 cu.m, 0.12 cu.m & 0.18 cu.m
- 6 in 1 clam shovel
- Ditch cleaning bucket
- Taper ditching bucket
- Square hole bucket
- Rock breaker
- Ripper tooth
- Heavy-duty rear tyres 14x25
- Auger
- Intelli Dig

## INDUSTRY'S FINEST CUSTOMER SUPPORT NETWORK

**65+**  
Dealers

**700+**  
Outlets

**5000+**  
Trained service engineers

**5**  
Parts warehouses



**3000+**  
Mobile service engineers

**4**  
Training centres

**250+**  
Service vans

**24x7 Support**  
12 Languages

## EXTENSIVE PARTS SUPPORT

JCB genuine parts offer a comprehensive machine protection solution.



## JCB LOYALTY PROGRAM



Our loyalty programme is a reflection of our brand promise and our constant endeavour to offer you more than your expectations.

Instant membership card | Welcome kit  
Rewards points | Extended benefits  
Special programme features



## SMART & DIGITAL SUPPORT

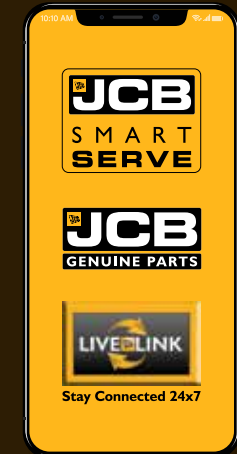

Download from:

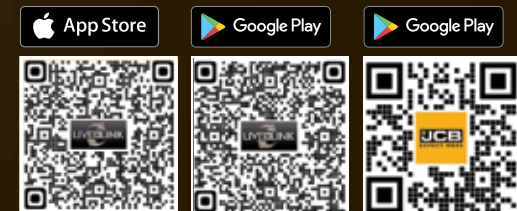

LiveLink

Genuine Parts

Dealer's stamp:

**JCB INDIA LIMITED** (Registered office)

B-1/1-1, 2nd Floor, Mohan Co - operative Industrial Estate,  
Mathura Road, New Delhi - 110 044

For more information SMS "JCB" to 56767 or call our toll free no. 1800-1037-386

Website: [www.jcb.com](http://www.jcb.com) | Follow us: [f](#) [t](#) [v](#) [i](#) [l](#) /JCBIndiaLtd

©2009 JCB Sales. All rights reserved. No part of this publication may be reproduced, stored in a retrieval system, or transmitted in any form or by any other means, electronic, mechanical, photocopying or otherwise, without prior permission from JCB Sales. All references in this publication to operating weights, sizes, capacities and other performance measurements are provided for guidance only and may vary dependant upon the exact specification and usage of machine. They should not therefore be relied upon in relation to suitability for a particular application. Guidance and advice should always be sought from your JCB Dealer. JCB reserves the right to change specifications without notice. Illustrations and specifications shown may include optional equipment and accessories. The JCB logo is a registered trademark of J C Bamford Excavators Ltd.

